

NOTE: 1  
DESIGN CODE:  
N/A

NOTE: 2  
TECHNICAL CLASSIFICATION:  
Article Type: 003-Valve Stabs  
Main Group: 3.07. Ø55/Ø57-Valvestab  
Intermediate Group: 3.42.01. Stab  
Sub Group: 3.42.102.6. Hexa

NOTE: 3  
INTERFACE INFORMATION:  
Pressure Rating Bar: 1.5/10  
Design Water Depth:  
Material: Intervention  
Weight: 3,4 kg  
Volume: 1,02 dm<sup>3</sup>  
Submerged Weight: 2,33 kg  
Surface Area: 2078 cm<sup>2</sup>  
Hydraulic: 3/8" BSP  
Mechanical: D-Handle  
Electrical: N/A  
Com. & Protocol: N/A

NOTE: 4  
ADDITIONAL INFORMATION:  
Protection Stab with Pressure Relief Valve to Prevent Internal Overpressure in Subsea Piping and Receptacles.  
Opening Pressure 1,5Bar. Soft Seal. Max Outer/External Overpressure 10Bar.  
Additional 3/8" BSP Port for Pressure Testing or Installation of Inlet Relief Valve.  
Contact Blue Logic AS for Alternative Configurations.

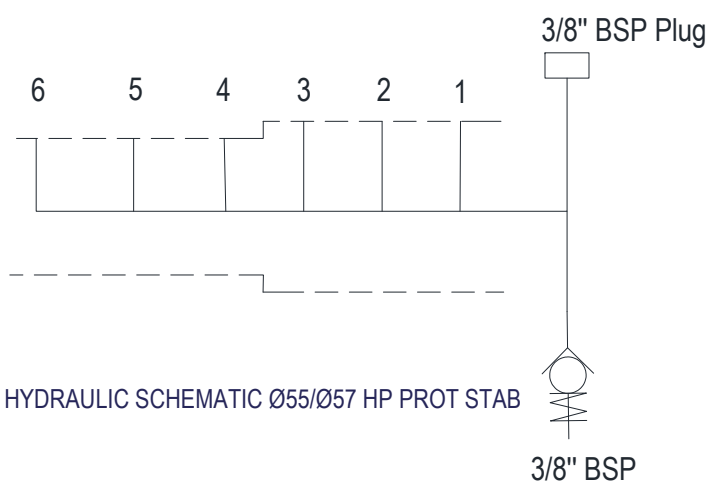
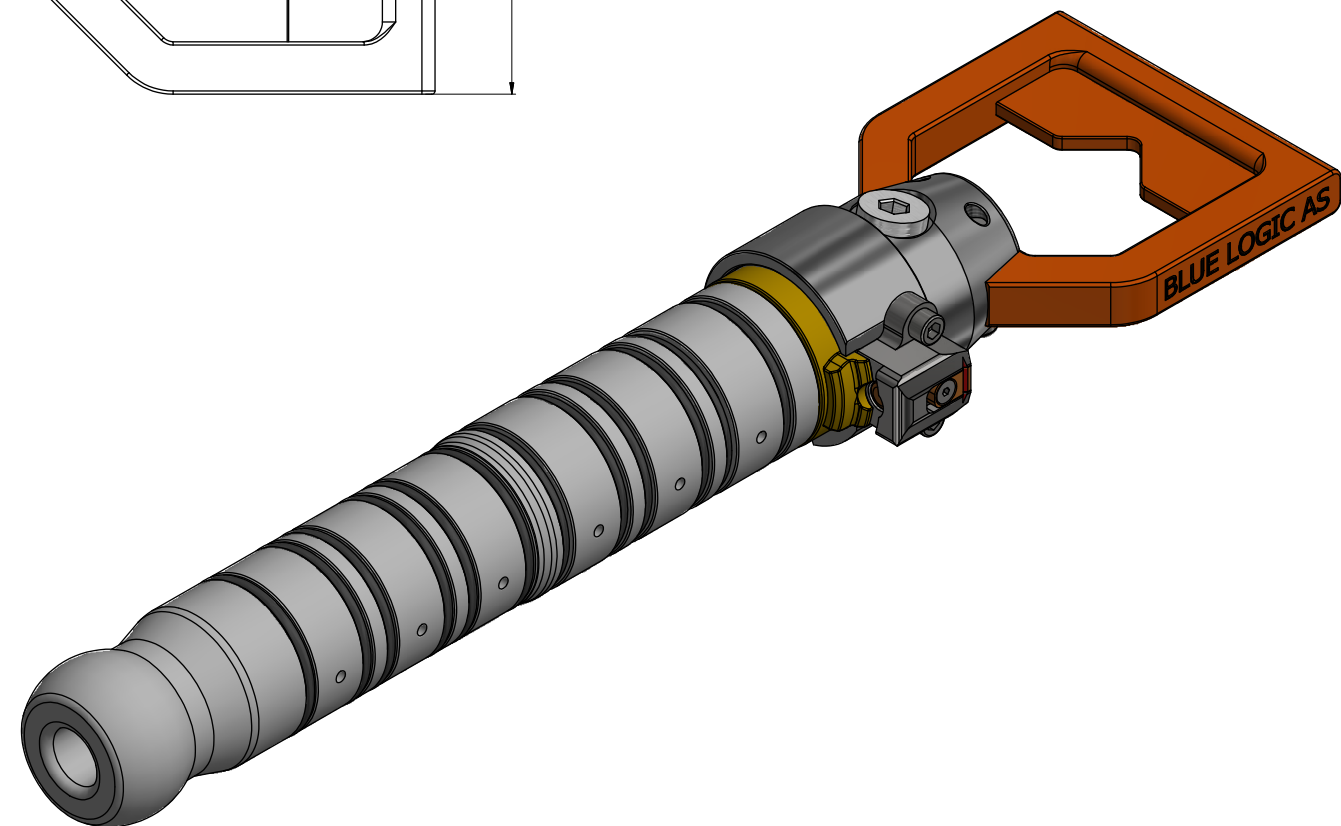

05	13.9.2024	9-IFU (Issued for Use)		HNJ	LGH	HNJ
04	17.1.2019	9-IFU (Issued for Use)		WTJ	LGH	WTJ
03	11.4.2018	9-IFU (Issued for Use)		WTJ	LAE	WTJ
02	27.3.2018	9-IFU (Issued for Use)		WTJ	HNJ	LGH
Rev.	Date	Reason for issue	Revision change	Made	Chk'd	Appr.



Dwg Scale: NTS  
Dwg Proj:

Drawing title: Ø55/Ø57 HP Prot VStab wRelief Valve 3/8" BSP

Dwg Format: A3

Drawing number: BB1322

Rev: 05